

# AH500 Panel Cut-out

Viewed from rear

(scale 1:1)

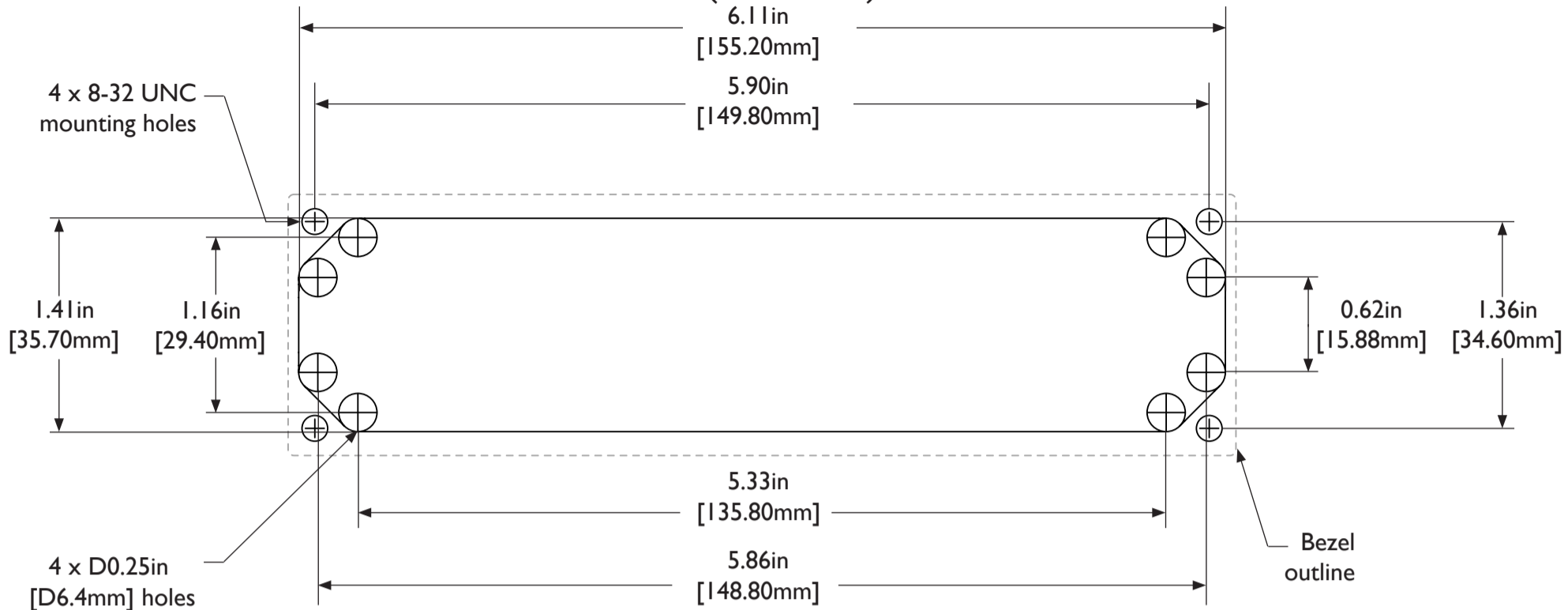

## Physical Dimensions

Not to scale

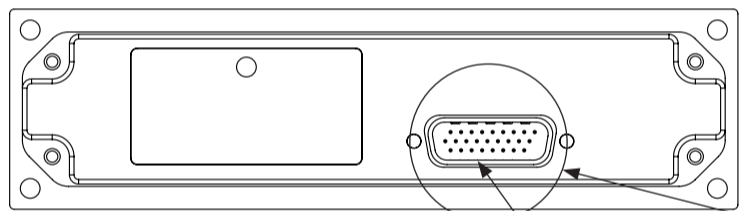
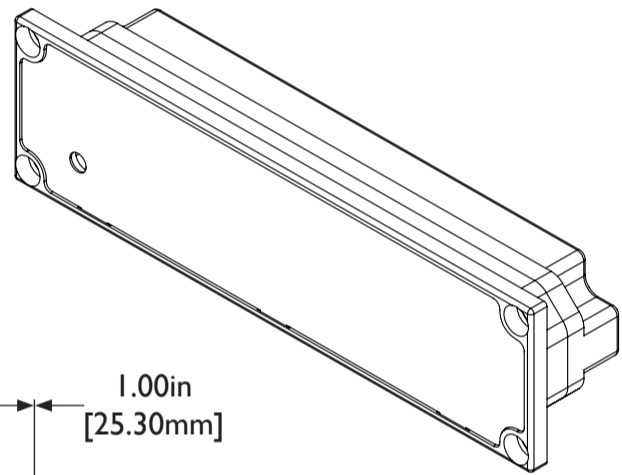
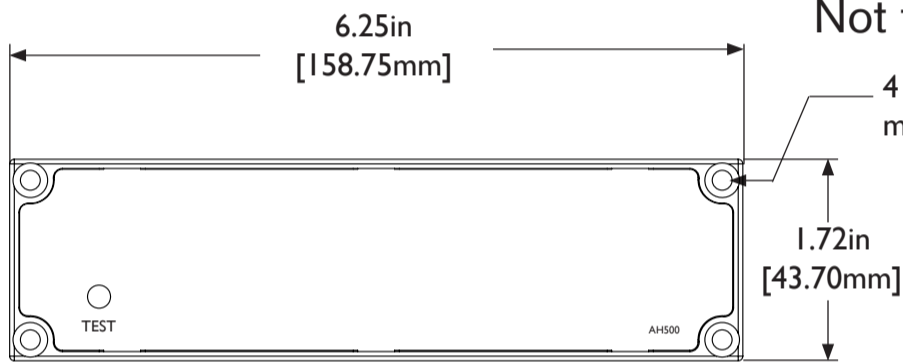

D-SUB 26 pin male connector

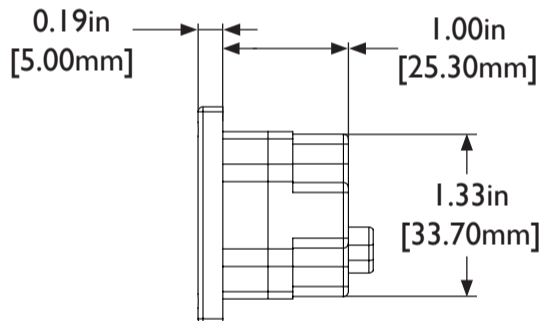

PIN	DESC	TYPE	CONNECT TO
1	+ve Power	10 to 32V	Aircraft +ve bus
2	Ground	GND	Aircraft GND
3	Digital Input 0	Volt Free Digital Input	
4	Digital Input 1 / RS-232 TX	Volt Free Digital Input or (+/- 5V) EIA/TIA-232 *	AH504 RX Pin 25
5	Analogue Input 0	0 to 32V	
6	Analogue Input 1	0 to 32V	
7	Digital Input 2 / RS-232 RX	Volt Free Digital Input or (+/- 5V) EIA/TIA-232 *	AH504 TX Pin 26
8	Digital Input 3	Volt Free Digital Input	
9	Analogue Input 2	0 to 32V	
10	Acknowledge Input	Volt Free Digital Input	AH501 Pin 1
11	AH501 'Warning' Sink	LED AH501 PWM Current sink	AH501 Pin D
12	Digital Input 4	Volt Free Digital Input	
13	Digital Input 5	Volt Free Digital Input	
14	Digital Input 6	Volt Free Digital Input	
15	Digital Input 7	Volt Free Digital Input	
16	Digital Input 8	Volt Free Digital Input	
17	Analogue Input 3	0 to 32V	
18	Digital Input 9	Volt Free Digital Input	
19	V LED Out	AH501 VLED (10V)	AH501 Pin E & F
20	AH501 'Caution' Sink	LED AH501 PWM Current sink	AH501 Pin C
21	Digital Input 10	Volt Free Digital Input	
22	Audio Hi		
23	0V		
24	Digital Input 11	Volt Free Digital Input	
25	RS-232 RX	(+/- 5V) EIA/TIA-232	EFIS/EMS TX
26	RS-232 TX	(+/- 5V) EIA/TIA-232	EFIS/EMS RX

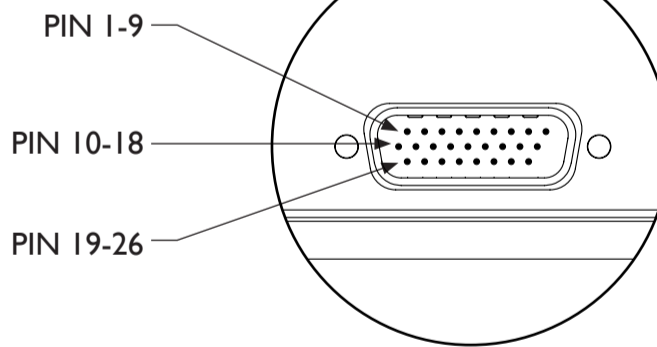

## AH500 Fitting instructions



Rendered Image (scale 1:1)

[www.aerosafety.com](http://www.aerosafety.com)



Example captions only

\* Pin 4 and 7 configurable at time of build only

Weight 7.1oz (205 grams)